



LC 1209

60V Input / 5V Output Linear Regulator

DESCRIPTION

LC1209 is a three-terminal positive regulator with an output voltage of 5.0V and output current up to 100mA. The device features a typical output tolerance of $\pm 5\%$. And its input voltage can stand a voltage as high as 60V.

LC1209 includes high accuracy voltage reference, error amplifier, TSD circuit and output driver module.

LC1209 offers thermal shut down functions to assure the stability of chip and power system.

LC1209 is available in SOT89-3, TO-92 and TO-220 power packages.

FEATURES

- Maximum output current up to 100mA
- Output voltage tolerances of $\pm 5\%$ over the temperature range
- Internal thermal over-temperature protection
- High input voltage (up to 60V)
- Low Power Consumption: 80uA (Typ.)
- Available in plastic TO-92 and plastic TO-220 packages
- No external components

APPLICATIONS

- Battery Powered equipment
- Communication equipment
- Audio/Video equipment

TYPICAL APPLICATION

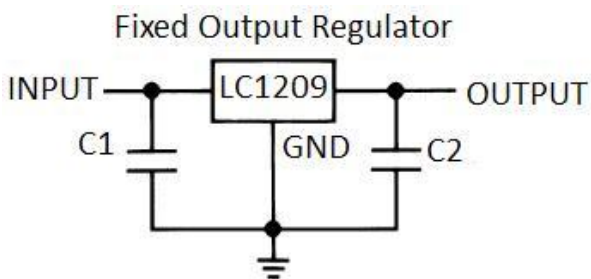

Application circuit of LC1209

NOTE: Input capacitor ($C1=0.33\mu F$) and Output capacitor ($C2=0.1\mu F$) are recommended in all application circuit. Tantalum capacitor is recommended.

ELECTRICAL CHARACTERISTICS

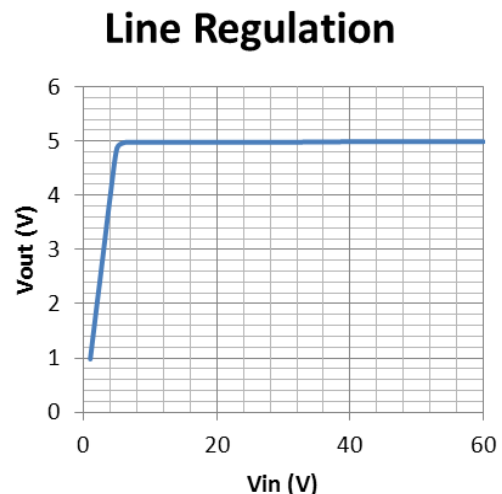

ORDERING INFORMATION

LC1209 [1](#) [2](#) [3](#) [4](#) [5](#)

Code	Description
1	Temperature&RoHS: C:-40~85°C ,Pb Free RoHS Std.
2	Package type: C3:SOT-89-3 H:TO-92 N: TO220
3	Packing type: TR:Tape&Reel (Standard) BG:Bag (TO-92)
4	Output voltage: e.g. 11=1.1V 15=1.5V 55=5.5V
5	Voltage accuracy: 2=±2% Blank(default)=±5%

PIN CONFIGURATION

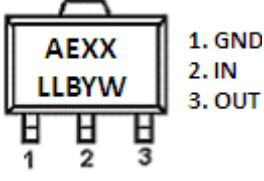
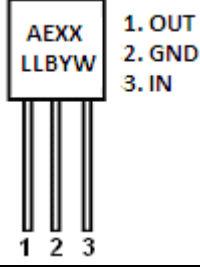
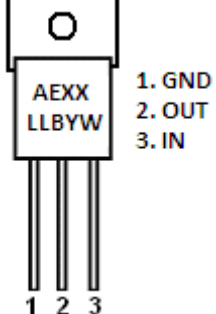
Marking Explanation		LC1209CC3TR50 SOT89-3
AEXX LLBYW	N: Product Code	
	XX: Output Voltage	
	LL: LOT NO.	
	B: FAB Code	
	YW: Date Code	
Marking Explanation		LC1209CHBG50 TO92
AEXX LLBYW	N: Product Code	
	XX: Output Voltage	
	LL: LOT NO.	
	B: FAB Code	
	YW: Date Code	
Marking Explanation		LC1209CHBG50 TO220
AEXX LLBYW	N: Product Code	
	XX: Output Voltage	
	LL: LOT NO.	
	B: FAB Code	
	YW: Date Code	

RECOMMENDED WORK CONDITIONS

Parameter	Value
Input Voltage Range	7V - 60V
Operating Junction Temperature(Tj)	-20°C -85°C

ABSOLUTE MAXIMUM RATING

Parameter		Value
Max Input Voltage		60V
Max Output Current		100mA
Operating Junction Temperature(Tj)		150°C
Ambient Temperature(Ta)		-40°C –85°C
Power Dissipation	TO-92	0.5 W
	TO-220	1 W
	SOT89-3	0.5W
Storage Temperature(Ts)		-40°C -150°C
Lead Temperature & Time		260°C, 10s

Note:

- Exceed these limits may cause damage to the device.
- Exposure to absolute maximum rating conditions may affect device reliability.

ELECTRICAL CHARACTERISTICS

(Test Conditions: $C_{in}=0.33\mu F, C_{out}=0.1\mu F, T_A=25^\circ C$, Unless otherwise specified.)

Symbol	Parameter	Conditions	Min	Typ	Max	Unit
Vin	Input Voltage				60	V
Vout	Output Voltage	$1mA \leq I_{out} \leq 40mA$ $7V \leq V_{in} \leq 20V$	4.75	5.0	5.25	V
ΔV_{out}	Line Regulation	$7V \leq V_{in} \leq 20V$	-	-	200	mV
ΔV_{out}	Load Regulation	$1mA \leq I_{out} \leq 100mA$	-	-	150	mV
Iout(Max.)	Maximum Output	$V_{in} - V_{out} = 1.5V$	100			mA
Iq	Quiescent Current	$V_{in} - V_{out} = 1.25V$	-	0.08	0.15	mA
$\Delta V / \Delta T$	Temperature coefficient	$V_{in} = 6.5V,$ $25^\circ C \leq Temp \leq 85^\circ C$			± 100	ppm
TSD	Over Temperature	$V_{in} = 6.5V, I_{out} = 1mA$	150			°C
θ_{JC}	Thermal Resistor	TO-92		10		°C / W
		TO-220		4.5		
		SOT89-3		20		

Note1: All test are conducted under ambient temperature 25°C and within a short period of time 20ms

BLOCK DIAGRAM

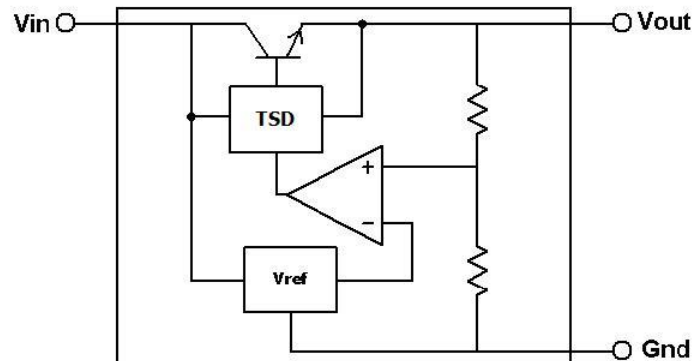

Fig.1 Block Diagram

EXPLANATION and THERMAL CONSIDERATION

LC1209 is a series of low dropout voltage and low power consumption regulator. Its application circuit is very simple, which only needs two outside capacitors.

We have to take heat dissipation into great consideration when voltage of input is high. Because in such cases, the power dissipation consumed by LC1209 is very large. LC1209 uses SOT-89-3 package type and its thermal resistance is about $20^{\circ}\text{C}/\text{W}$. And the copper area of application board can affect the total thermal resistance. If copper area is $5\text{cm} \times 5\text{cm}$ (two sides), the resistance is about $30^{\circ}\text{C}/\text{W}$. So the total thermal resistance is about $20^{\circ}\text{C}/\text{W} + 30^{\circ}\text{C}/\text{W}$. We can decrease total thermal resistance by increasing copper area in application board. When there is no good heat dissipation copper are in PCB, the total thermal resistance will be as high as $120^{\circ}\text{C}/\text{W}$, then the power dissipation of LC1209 could allow on itself is less than 1W. And furthermore, LC1209 will work at junction temperature higher than 125°C under such condition and no lifetime is guaranteed.

TYPICAL PERFORMANCE CHARACTERISTICS

($T=25^{\circ}\text{C}$ unless specified.)

Line Regulation

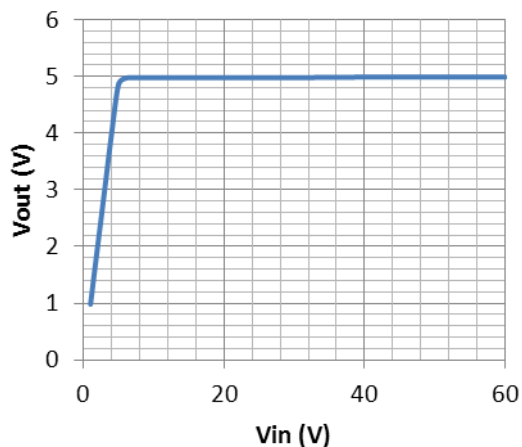

Load Regulation

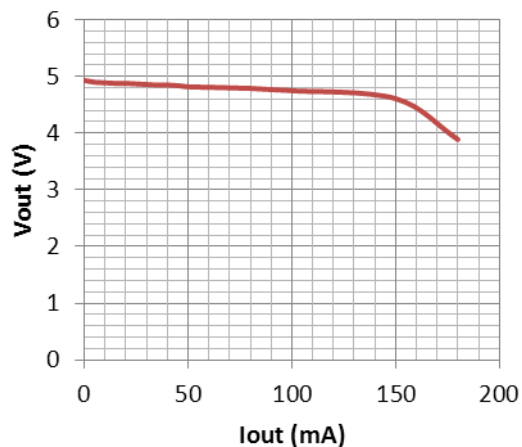

Temperature Coefficient

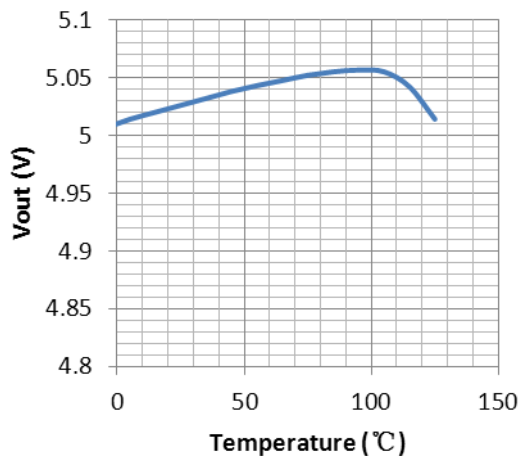

TSD (Thermal Shutdown)

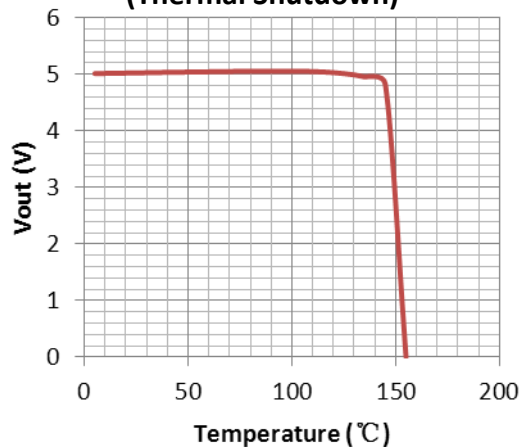

PACKAGE OUTLINE

Package	TO-92	Device per Box	1000	Unit	mm
Package specification:					
<p>Technical drawing of the TO-92 package. The front view shows a circular body with a diameter of 5.2 mm (4.7 mm tolerance) and a height of 5.2 mm (4.9 mm tolerance). An EJECTION MARK is located at the top center with a diameter of 1.6 mm MAX and a depth of 0.38 mm MAX. The package has three leads with a length of 14.2 mm (12.7 mm tolerance) and a width of 2.54 ± 0.1 mm. The lead thickness is 0.55 mm TYP and 0.40 mm. The distance between leads is 1.27 ± 0.05 mm. The side view shows a diameter of 4.19 mm (3.65 mm tolerance) and a SEATING PLANE. The lead diameter is 2.29 mm MAX (UNCONTROLLED LEAD DIA) and the lead thickness is 0.50 mm (0.36 mm tolerance). The cross-sectional view shows a diameter of 2.27 mm (2.10 mm tolerance) and a lead thickness of 0.40 mm. DIMENSIONS ARE IN MILLIMETERS.</p>					

Package	SOT-89-3	Devices per reel	1000	Unit	mm
Package specification:					
<p>Technical drawing of the SOT-89-3 package. The front view shows a rectangular body with a width of 4.5 ± 0.1 mm and a height of 4.25 mm MAX. The package has three leads with a length of 1.6 ± 0.2 mm and a width of 0.4 mm. The lead thickness is 0.8 mm MIN. The side view shows a width of 1.5 ± 0.1 mm and a height of 0.4 ± 0.1 mm. The top view shows a width of 1.5 ± 0.1 mm and a height of 0.47 ± 0.1 mm. The distance between leads is 0.42 ± 0.2 mm. The package has a diameter of 1.0 mm. DIMENSIONS ARE IN MILLIMETERS.</p>					

PACKAGE OUTLINE (Continued)

Package	TO-220	Devices per reel		Unit	mm
Package specification:					
<p>The technical drawing illustrates the TO-220 package specifications. The top view shows a rectangular body with a width of 9.90 ± 0.20 mm and a length of 13.08 ± 0.20 mm. A central circular feature has a diameter of $\phi 3.60 \pm 0.10$ mm. The side view shows a total height of 18.95 mm (maximum), with a body height of 15.90 ± 0.20 mm and a lead height of 10.08 ± 0.30 mm. The bottom view shows a width of 10.00 ± 0.20 mm. Lead dimensions include a pitch of 2.54 TYP ($[2.54 \pm 0.20]$) mm, a lead thickness of $0.50^{+0.10}_{-0.05}$ mm, and a lead width of 2.40 ± 0.20 mm. A 45° chamfer is indicated on the lead tip.</p>					

 代理商：深圳市琪远电子有限公司
 电话：(0755)86228541 / 17727576605
 更多产品请访问：www.siitek.com.cn